



ISSN: 2249-7315

Vol. 11, Issue 10, October 2021

SJIF –Impact Factor = 8.037 (2021)

DOI: 10.5958/2249-7315.2021.00096.4

AUTOMATED SEED SOWING MACHINE: A REVIEW

Mr. Ajay Agrawal*

*SOEITS, Sanskriti University,
Mathura, Uttar Pradesh, INDIA

Email id: ajayagrawal.me@sanskriti.edu.in

ABSTRACT

In the farming process, often used conventional seeding operation takes more time and more labor. The seed feed rate is more but the time required for the total operation is more and the total cost is increased due to labor, hiring of equipment. The conventional seed sowing machine is less efficient, time consuming. Today's era is marching towards the rapid growth of all sectors including the agricultural sector. To meet the future food demands, the farmers have to implement the new techniques which will not affect the soil texture but will increase the overall crop production. In the farming process, often used conventional seeding operation takes more time and more labor. The seed feed rate is more but the time required for the total operation is also more and the total cost is increased due to labor, hiring of equipment. This machine reduces the efforts and total cost of sowing the seeds and fertilizer placement. Sowing machine should be suitable to all farms, all types of crops, robust construction, also it should be reliable, this is basic requirement of sowing machine. Thus we made sowing machine which is operated manually but reduces the efforts of farmers thus increasing the efficiency of planting also reduces the problem encountered in manual planting. For this machine we can plant different types and different sizes of seeds also we can vary the space between two seeds while planting. This also increased the planting efficiency and accuracy. We made it from raw materials thus it was so cheap and very usable for small scale farmers. For effective handling of the machine by any farmer or by any untrained worker we simplified its design. Also its adjusting and maintenance method also simplified.

KEYWORDS: Agriculture, Crop, Fertilizer, Machine, Seeds

1. INTRODUCTION

In the current generation most of the countries do not have sufficient skilled man power especially in agricultural sector and it affects the growth of developing countries. The main requirement of Automation is to reduce man power in our country; the buzzword in all industrial firms generally involves electrical, electronic component as well as mechanical part. Automation saves a lot of tedious manual work and speeds up the production processes. So it is a time to automate the sector to overcome this problem. In India there are 70% people

dependent on agriculture. Seed has been an important agricultural commodity since the first crop plant was domesticated by pre-historic man. In this model seed sowing process is automated to reduce the human effort and increase the yield. The plantation of seeds is automatically done by using DC motor[1].

Cropping is important and tedious activity for any farmer, and for large scale this activity is so lengthy also it needs more workers. Thus agriculture machines were developed to simplify the human efforts. In manual method of seed planting, we get results such as low seed placement, less spacing efficiencies and serious back ache for the farmer. This also limited the size of field that can be planted. Hence for achieving best performance from a seed planter, the above limits should be optimized. Thus we need to make proper design of the agriculture machine and also selection of the components is also required on the machine to suit the needs of crops. The agriculture is the backbone of India. And for sustainable growth of India development of agriculture plays vital role. The India has huge population and day by day it is growing thus demand of food is also increasing. In agriculture we saw various machines. Also there traditional methods are there. Since long ago in India traditional method is used. Also India has huge man power. This manual planting is popular in villages of India. But for large scale this method is very troublesome. The farmer has to spend his more time in planting. But time available is less for him. Thus it requires more man power to complete the task within stipulated time which is costlier. Also more wastage happens during manual planting. Hence there is need of developing such a machine which will help the farmer to reduce his efforts while planting. This process of using machines is called as mechanization. Along with mechanization automation also helps to increase the efficiency of the process[2].

The robotic system is an electromechanical (conveys a sense that it has agency of its own) and artificial agent which is steered by DC motor which has four wheels. The farm is cultivated by the machine, depending on the crop considering particular rows & specific columns. The infrared sensor detects the obstacles in the path and it also senses turning position of vehicle at end of land. The seed block can be detected and solved using water pressure. The machine can be controlled remotely and solar panel is used to charge DC battery. Assembly language is used in programming the microcontrollers. The microcontroller is used to control and monitor the process of system motion of vehicle with the help of DC motor. As agriculture is extensively supported by technical means like seeding, mowing or harvesting machines, it is widely considered to be a field with a high potential for robotic application as it is a small step from these semi automatically operated machines to fully autonomous robots in both greenhouse and open field applications. Robots are available on all development levels from experimental to market-ready in several agricultural applications but most of them are in research, where institutes have made progress to extend the existing agricultural machines to robotic systems. Most of the robots considered in this publication are developed for harvesting. Seeding is not yet as important since there are already good tractor based seeding systems. In horticulture there are significantly less robotic applications as in agriculture[3].

1.1 Traditional Sowing Methods:

Traditional methods include broadcasting manually, opening furrows by a country plough and dropping seeds hand, known as ‘Kera’, and dropping seeds in the furrow through a bamboo/mental funnel attached to a country plough(Pora). For sowing in small areas dibbling i.e., making holes or slits by a stick or tool and dropping seeds by hand, is practiced. Multi row traditional seeding device with manual metering of seeds are quite popular with experienced farmers. Traditional sowing methods have following limitations;

- In manual seeding, it is not possible to achieve uniformity in distribution of seeds. A farmer may sow at desired seed rate but inter- row and intra – row distribution of seeds is likely to be uneven resulting in bunching and gaps in field.

- Poor control over depth of seed placement.
- It is necessary to sow at high seed rates and bring the plant population to desired level by thinning.
- Labour requirement is high because two persons are required for dropping seed and fertilizer.
- The effect of inaccuracies in seed placement on plant stand is greater in case of crops sown under dry farming conditions.

During kharif sowing, placement of seeds at uneven depth may result in poor emergence because subsequent rains bring additional soil cover over the seed and affect plant[4].

2. LITRATURE REVIEW

Thorat Swapnil V in his study discloses about sowing machine which is operated manually but lowers the efforts of farmers therefore improving the efficiency of planting and eliminates the issue faced in manual planting. For this machine we can plant various kinds and different sizes of seeds furthermore we can change the distance between two seeds during planting. This also improved the planting efficiency and precision. We built it using raw materials thus it was very inexpensive and extremely useful for small scale farmers. For efficient handling of the equipment by any farmer or by any unskilled person we reduced its design. Is its adjusting and maintenance procedure also simplified[5].

G.Spandana in her recent study discloses about available information technology in the form of more intelligent devices to minimize and focus energy inputs in more effective ways than in the past. Our project mainly focuses to enhance the agricultural equipment as per contemporary system. We are going to introduce plough out of tractor operated by connecting with microcontroller. By utilizing this equipment seed can be so simply with more specifications, sprinkling and cutting can be done[6].

Bhushan Deshmukh in his study discloses about traditional sowing process that requires more time and more effort. The seed feed rate is higher but the time needed for the entire operation is larger and the overall cost is raised owing to labor, hiring of equipment. The traditional seed sowing equipment is less efficient, time demanding. Today's age is marching towards the fast development of all sectors including the agriculture industry. To fulfill the future food demands, the farmers have to adopt the new methods which will not damage the soil texture but will increase the total crop output. In the agricultural process, commonly utilized traditional seeding procedure takes more time and more work. The seed feed rate is higher but the time needed for the entire operation is also more and the overall cost is raised owing to manpower, renting of equipment. This equipment lowers the efforts and overall cost of planting the seeds and fertilizer placement[7].

3. DISCUSSION

3.1 Working principle:

The Automated seed sowing technology is a method design in order to reduce the human efforts as it requires less amount of manmade labour and can be handle efficiently without a skilled operator. Seeding manually requires lots of time, therefore this technology develops which eradicated much amount of time with proper efficiency, less time consuming, accuracy in sowing seed at specific distance. It works on simple mechanism, a battery operated D.C. motor is used transmits the rotary motion to the shaft with the help of chain drive, and there is another connection of sprocket and chain to the rotary motion. When the farmer puts seeds into the hopper as the seed rotates, seed drops in the seed pipe, which is connected to the furrow opener for the seeding; there is furrow closer for covering the seeds by soil. Figure 1 represents the traditional Sowing machine and figure 2 represents experimental setup of automated seed sowing machine[8].

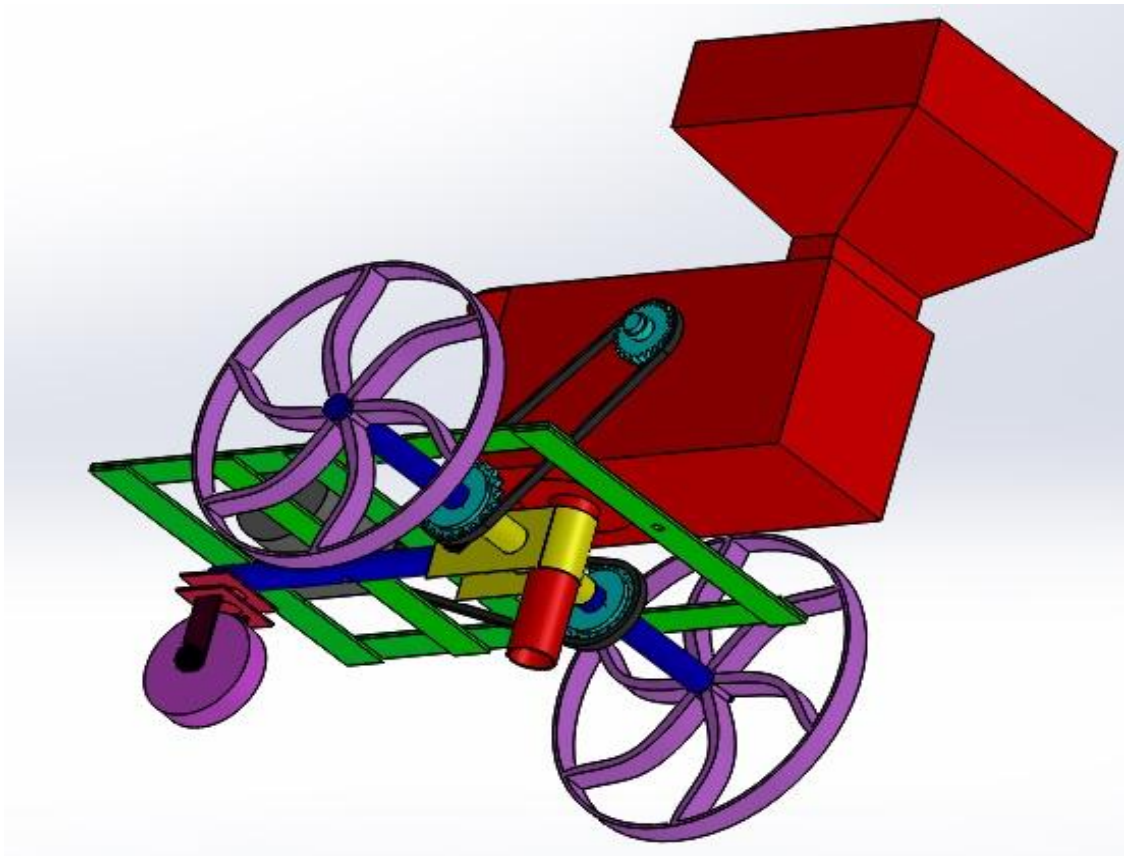

Figure 1: Traditional Sowing machine[8].

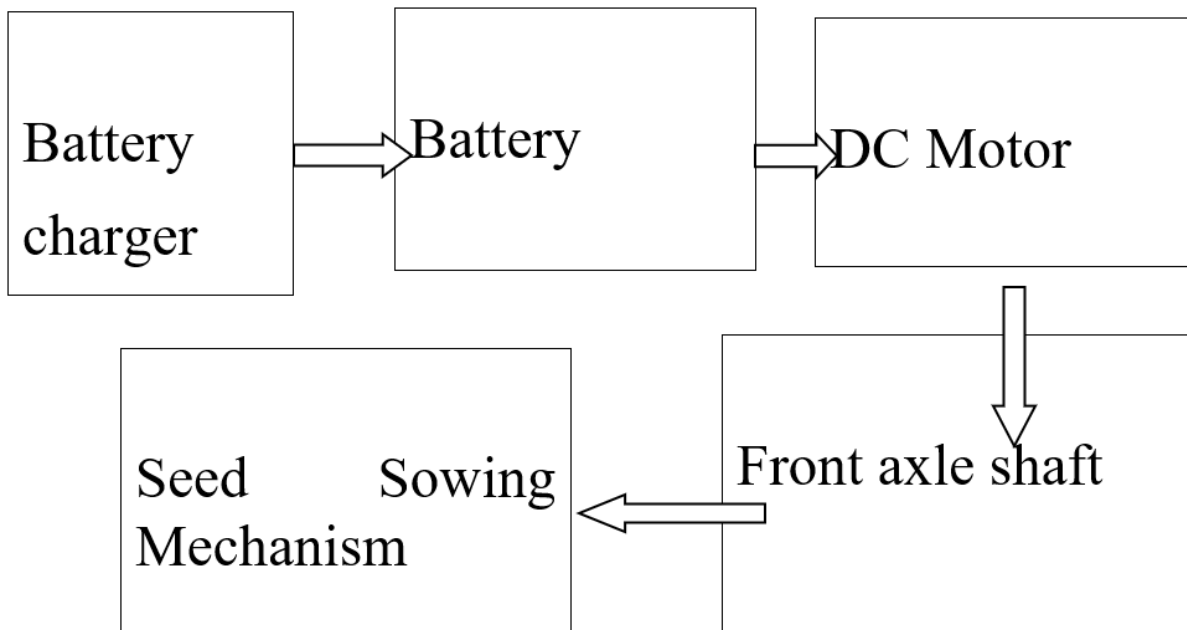

Figure 2: Experimental Setup of automated seed sowing machine[8].

3.2 Machining:

3.2.1 Drilling:

- Creates a round hole in a work part.
- Contrasts with boring which can only enlarge an existing hole.
- Cutting tool called a drill or drill bit.
- Customarily performed on a drill press.

- Counter boring Provides a stepped hole, in which a larger diameter follows a smaller diameter partially into the hole.
- Figure 3 represents the drilling method of sowing machine.

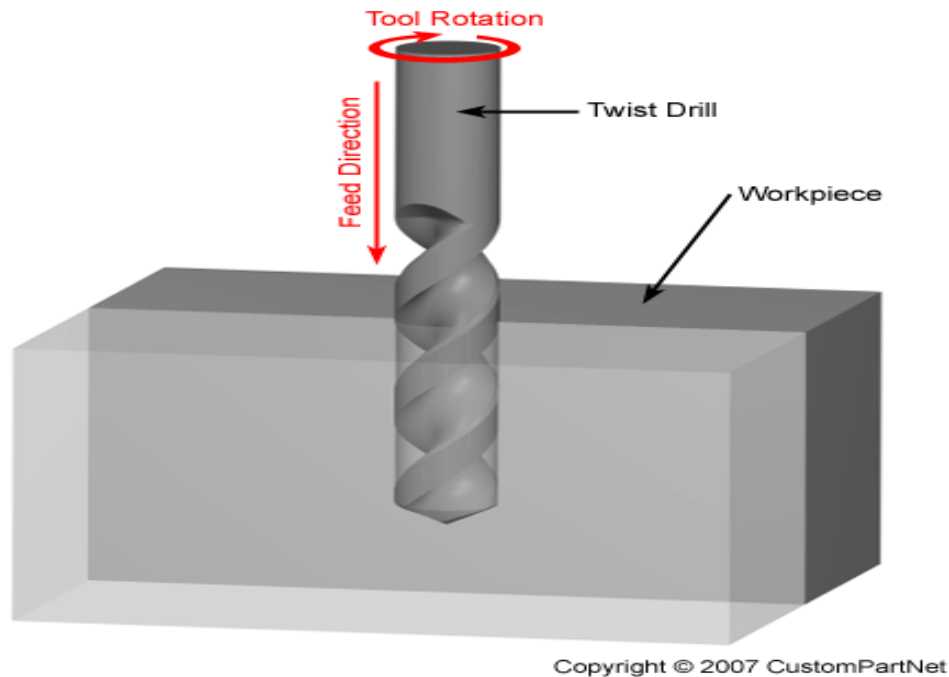

Figure 3: Driller method of seed sowing machine[9]

3.2.2 Welding:

Welding is a fabrication or sculptural process that joins materials, usually metals or thermoplastics by using high heat to melt the parts together and allowing them to cool causing fusion. Welding is distinct from lower temperature metal-joining techniques such as brazing and soldering, which do not melt the base metal. In addition to melting the base metal, a filler material is typically added to the joint to form a pool of molten material (the weld pool) that cools to form a joint that, based on weld configuration (butt, full penetration, fillet, etc.), can be stronger than the base material (parent metal). Pressure may also be used in conjunction with heat, or by itself, to produce a weld. Welding also requires a form of shield to protect the filler metals or melted metals from being contaminated or oxidized. **Arc welding** is a welding process that is used to join metal to metal by using electricity to create enough heat to melt metal, and the melted metals when cool result in a binding of the metals. It is a type of welding that uses a welding power supply to create an electric arc between a metal stick ("electrode") and the base material to melt the metals at the point-of-contact. Arc welders can use either direct (DC) or alternating (AC) current, and consumable or non-consumable electrodes. Figure 4 represents the welding process of seed sowing machine[10].

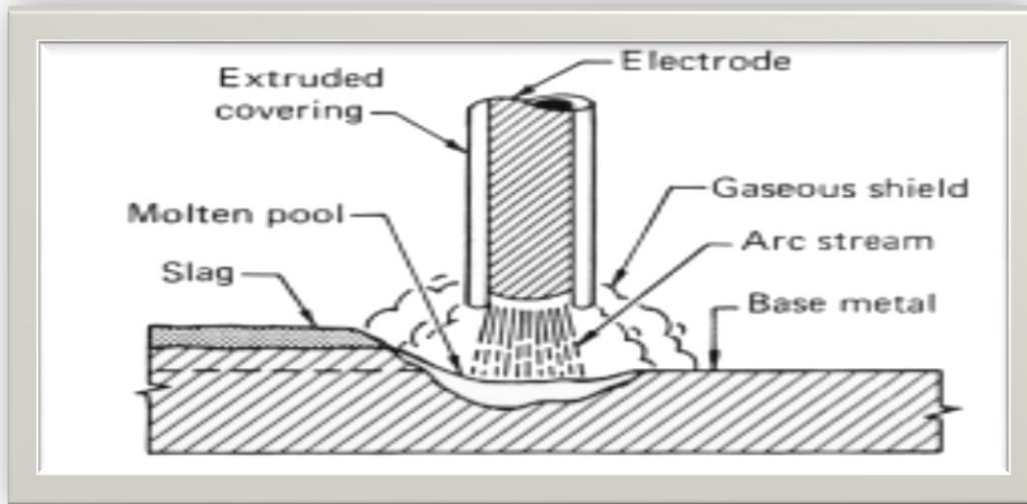

Figure 4: welding process of seed sowing machine[10].

3.2.3 Cutting:

Cutter is any tool that is used to remove material from the work piece by means of shear deformation. Cutting may be accomplished by single-point or multipoint tools. Single-point tools are used in turning, shaping, planing and similar operations, and remove material by means of one cutting edge. Milling and drilling tools are often multipoint tools. Grinding tools are also multipoint tools. Each grain of abrasive functions as a microscopic single-point cutting edge (although of high negative rake angle), and shears a tiny chip.

Cutting tool materials must be harder than the material which is to be cut, and the tool must be able to withstand the heat generated in the metal-cutting process. Also, the tool must have a specific geometry, with clearance angles designed so that the cutting edge can contact the work piece without the rest of the tool dragging on the work piece surface. The angle of the cutting face is also important, as is the flute width, number of flutes or teeth, and margin size. In order to have a long working life, all of the above must be optimized, plus the speeds and feeds at which the tool is run[3].

3.2.4 Bending:

A bending machine is a forming machine tool. Its purpose is to assemble a bend on a work piece. A bend is manufactured by using a bending tool during a linear or rotating move. The detailed classification can be done with help of the kinematics[5].

3.2.5 Counter boring:

A counterbore is a cylindrical flat-bottomed hole that enlarges another coaxial hole, or the tool used to create that feature. A counterbore hole is typically used when a fastener, such as a socket head cap screw, is required to sit flush with or below the level of a workpiece's surface. Whereas a counterbore is a flat-bottomed enlargement of a smaller coaxial hole, a countersink is a *conical* enlargement of such. A spotface often takes the form of a very shallow counterbore. As mentioned above, the cutters that produce counterbores are often also called counterbores; sometimes, to avoid ambiguity, the term **counterbore cutter** is used instead. Table 1 represents the cost estimation of every parts of the machine[6].

TABLE 1: REPRESENTING THE COST ESTIMATION

SR.No	Parts Name	Cost In Rs
1.	Motor (12V 100RPM)	2000
2.	Chain	500
3.	Charger	750
4.	Battery (12V 9Ah)	2000
5.	Gears	3000
6.	Plates	400
7.	Rods	1800
8.	Fabrication Of Assembly With Components (body)	3000
9.	Miscellaneous cost	500
	Total	13950

3.3 Advantages:

- These machines are adequately designed with auto seed feeding system planting channel for optimal growing conditions.
- Adjustable seeding rate.
- Seed monitor and hectare counter.
- Spring loaded plunger for seed dropping.
- No extra manpower required.
- It is compact in size[8].

3.4 Application:

- Farming The design of furrow openers of seed drills varies to suit the soil conditions of particular region. Most of the seed cum fertilizer drills are provided with pointed tool to form a narrow slit in the soil for seed deposition.
- Gardening Seeds are broadcasted on the soil which results in the loss and damage of the seeds. As the cost of seeds is more and cannot be affordable for the farmers so there is the need for the proper placement of seeds in the soil.
- Sport's Stadium The fluted roller seed cup is having the arrangement of seed cut-off and controlling flap to control the amount of seeds and fertilizers.
- Agri Universities The Harrow is one of the important agricultural equipment which is used in the fields of agriculture for seed bed preparation and weed control. This is used before the seeds are sown in the field. This helps in the leveling of the soil and seeds can be sown in the prepare bed easily Polyhouse Seeds are broadcasted on the soil which results in the loss and damage of the seeds. As the cost of seeds is more and cannot be affordable for the farmers so there is the need for the proper placement of seeds in the soil[4].

4. CONCLUSION

This seed plantation machine has great potential for increasing the productivity of the planting. Till now tractor was the main traction unit for nourishment in farming. With the adaptation of this seed planting machine its purpose will be done. Hence there is need to promote this technology and made available to even small scale farmers with affordable prices. This machine can be made by raw materials also which saves the cost of whole project and is easily manufactured in available workshops. The only cost is of metering device and

sensors. Hence by using this machine we can achieve flexibility of distance and control depth variation for different seeds, hence usable to all seeds. Introduction of Cutter in place of drill can be used as grass cutter equipment.

- Using remote control machine can be made automatic.
- Addition of multi-hopper can be attached side by side for sowing of large farm.
- Water dripping unit could be included in seed sowing machine.

REFERENCES

1. M. J. P. M. R. T. M. N. R. M. W. H. Prof. and K. S.G5, "Solar Seed Sowing Machine," *Int. J. Sci. Res. Dev.*, vol. 3, no. 11, p. 3, 2016.
2. R. Kathiravan and P. Balashanmugam, "DESIGN AND FABRICATION OF MANUALLY OPERATED SEED SOWING MACHINE," *Int. Res. J. Eng. Technol.*, 2008.
3. A. R. Bhaisare C C Handa, "Design, Fabrication and Experimentation of Equidistant Seed Sowing Cum Fertilizer Machine," *IJIRST –International J. Innov. Res. Sci. Technol.*, 2015.
4. N. B. Adalinge, G. P. Ghune, G. B. Lavate, and R. R. Mane, "Impact factor: 4.295 Design and Manufacturing of Seed Sowing Machine," *Int. J. Adv. Res.*, 2017.
5. M. Shinde T.A., A. Shinde, and J. S. Awati, "Design and Development of Automatic Seed Sowing Machine," 2017.
6. T. A. Shinde and J. S. Awati, "Design and Development of Automatic Operated Seeds Sowing Machine," *SSRG Int. J. Electron. Commun. Eng. -*, 2017.
7. M. M N, "Solar Powered Digging and Seed Sowing Machine," *Int. J. Res. Appl. Sci. Eng. Technol.*, 2017, doi: 10.22214/ijraset.2017.3081.
8. R. V Marode, G. P. Tayade, and S. K. Agrawal, "Design and Implementation of Multi Seed Sowing Machine," *Int. J. Mech. Eng. Rob. Res*, 2013.
9. N. B. Adalinge, G. P. Ghune, G. B. Lavate, and R. R. Mane, "Design and Manufacturing of Seed Sowing Machine," *Int. J. Adv. Res.*, 2017.
10. R. Madhuri, S. Gorane, P. Ganesh, P. Shubham, and P. Nikhil, "MULTIPURPOSE SEED SOWING MACHINE," *Int. J. Adv. Technol. Eng. Sci.*, 2016.